



Proven Performance Since 1932.

SPILL CONTAINMENT MANHOLES

SPILL CONTAINMENT MANHOLE RING WITH TWO INTERCHANGEABLE COVERS

Application -

Designed to contain spillage during underground tank filling.

Part Number - 69RT & 71CD-SP

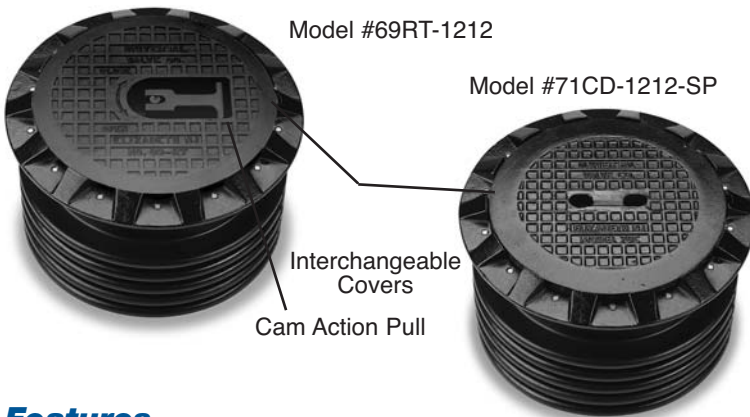

UNIVERSAL Advantage

Only from Universal! - Change covers as your needs change. Both the #69RT and #71CD-SP covers have a water-resistant seal. The 69RT features a cam action cover that pulls down on the seal for added protection. Both units also feature a cast iron base, (not plastic), that eliminates cross threading. The flexible bellows are fastened to the base with 8 bolts to eliminate the possibility of separation during ground shifts, which is associated with other containment manholes.

Features -

- ✓ Interchangeable Covers
- ✓ Gasketed all weather ring takes the abuse of snow plows
- ✓ 4" riser opening
- ✓ H-20 load rating
- ✓ Available with a flush mount ring

Construction -

- 71CD cover: ductile iron, 69RT cover: cast aluminum
- Cast iron ring
- Cross-linked polyethylene bellows
- Plastic gravel shield
- Cast iron base

Model	Gallon Capacity	Weight (lbs.)	A	B	C
69RT-1212	5	55.5	15"	15-1/2"	15-1/2"
69RT-1212-FM	5	55.5	15"	15-1/2"	15-1/2"
71CD-1212-SP	5	55.5	15"	15-1/2"	15-1/2"

Replacement Parts

Part Numbers	Description
69RT-CO	Raintight Cover
71-12-14	All Weather Cover(SP)
70CD-12-15	Drain Valve Screen
70CD-12-DA	Drain Valve Assembly
70CD-12-L	Knob

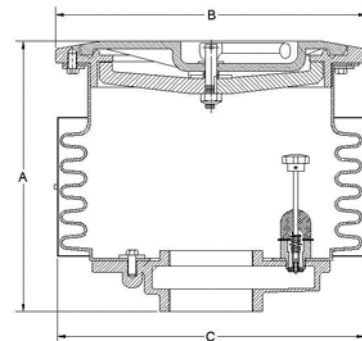

Notice: Universal Valve Co., products must be used in compliance with applicable federal, state, and local laws and regulations. Product selection should be based on physical specifications and limitations and compatibility with the environment and material to be handled. Universal Valve Co., makes no warranty of fitness for a particular use. All illustrations and specifications in this literature are based on the latest production information available at the time of publication. Prices, materials, and specification are subject to change at any time, and models may be discontinued at any time, in either case, without notice or obligation.

UNIVERSAL VALVE COMPANY

478 Schiller Street, Elizabeth, NJ 07206 • (800) 223-0741 • (908) 351-0606 • Fax: (908) 351-0369 • universalvalve.com

© 2009 Universal Valve Company, Inc.