



Family Owned Over 75 Years. We Care!

UNIVERSAL SIGNAGE SYSTEMS

THE BANK TELLER

Application -

The Universal Sign System Strategically Brings Your Customer Into The Bank...Ready To Use Your Services... Because It's The **ONLY** Sign System That Starts At The Drive-In Lane, And Finishes Inside The Bank.

Part Number - 1999 -Teller

**UNIVERSAL
Advantage**

Grab attention and increase your sales while economically utilizing existing space as part of a sign system.



Features -

- ✓ Highlights your Offers and Specials
- ✓ Grabs Attention
- ✓ Standard size 28" x 44"
- ✓ Custom Sizes Available
- ✓ Cross-sell Your Products 24/7
- ✓ Grabs Consumer Attention at Drive-In Lanes
- ✓ Insures Better Driving Mobility and Safety
- ✓ Easy front loading access for your message insert

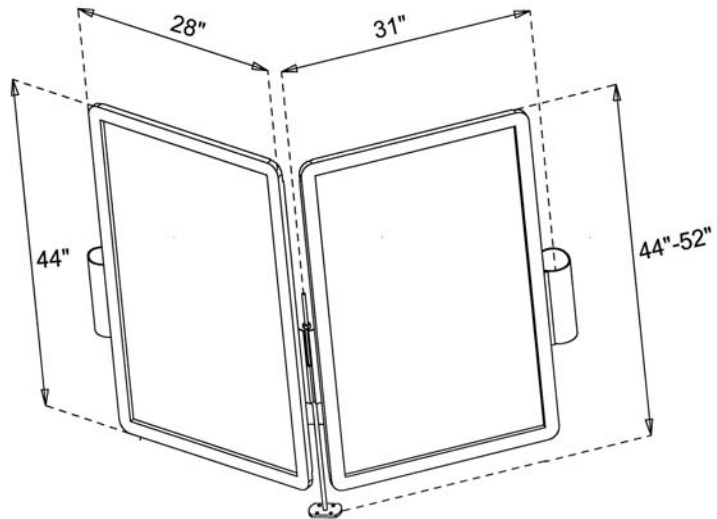

Construction -

- Epoxy coated steel frames
- Heavy duty spring clips
- Sign inserts available with any graphics, messages, and logos
- Standard rounded corners

Model#	Description	Weight (lbs.)
1999-TELLER	28" x 44" Bank Teller sign	38

Notice: Universal Valve Co., products must be used in compliance with applicable federal, state, and local laws and regulations. Product selection should be based on physical specifications and limitations and compatibility with the environment and material to be handled. Universal Valve Co., makes no warranty of fitness for a particular use. All illustrations and specifications in this literature are based on the latest production information available at the time of publication. Prices, materials, and specification are subject to change at any time, and models may be discontinued at any time, in either case, without notice or obligation.

UNIVERSAL VALVE COMPANY

478 Schiller Street, Elizabeth, NJ 07206 • (800) 223-0741 • (908) 351-0606 • Fax: (908) 351-0369 • universalvalve.com

© 2009 Universal Valve Company, Inc.