



Family Owned Over 80 Years. We Care!



SPILL CONTAINMENT MANHOLE

5 AND 15 GALLON DOUBLE WALL SPILL CONTAINMENT MANHOLE

Application -

Universal's "Quick Install" Double Wall Spill Container is designed to prevent water intrusion into the secondary containment. Bellows replacement is easy and eliminates the need to break concrete, providing efficient long service life.

Part Number - 71CD-DW

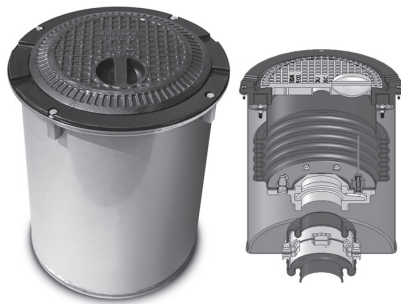

UNIVERSAL Advantage

Universal provides easy replacement bellows plus a full 15 gallon or 5 gallon capacity.

Features -

- ✓ Double walled to contain spilled product
- ✓ Easy replaceable bellows
- ✓ Monitoring port for secondary containment access
- ✓ 15 or 5 gallon primary containment
- ✓ Watertight cast iron ring
- ✓ Stainless steel combo primary buckets
- ✓ Available with primary and secondary slip on model (70C)
- ✓ Quick install
- ✓ Fully tested
- ✓ Fully assembled
- ✓ Compatible with E-85 (Model 70C)
- ✓ V model without drain

Construction -

- Ductile iron ring and cover
- Stainless steel secondary containment
- High density Polyethylene primary containment (71CD)
- Cast iron primary base (71CD)
- Pellethane penetration fitting

Model	A	B	C	Weight (lbs)
71CD-0512-DW	18.3"	21"	15.2"	119
71CD-1512-DW	18.3"	31"	25.5"	140
70C-0512-DW	18.3"	21"	15.2"	10
71CD-0512-V-DW	18.3"	21"	15.2"	119
71CD-1512-V-DW	18.3"	31"	25.5"	140

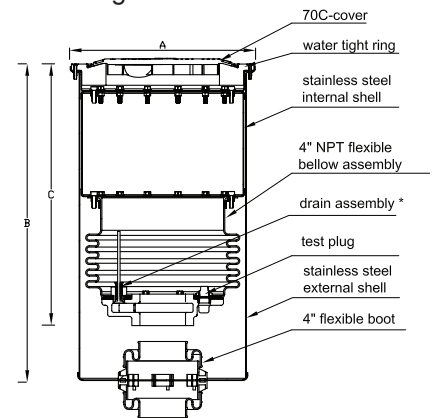

Replacement Parts

Part Numbers	Description	Part Numbers	Description
71CD-05-DW	Primary 71 Bucket	71-12-4	Ring Bolts
70C-12-A-DW	Primary 70C Bucket	71CD-BOOT	Flexible Boot
70C-12-K	Hardware Kit(70C)	71DW-04	Drain Valve Plug
70C-12CO	Cover		

Notice: Universal Valve Co., products must be used in compliance with applicable federal, state, and local laws and regulations. Product selection should be based on physical specifications and limitations and compatibility with the environment and material to be handled. Universal Valve Co., makes no warranty of fitness for a particular use. All illustrations and specifications in this literature are based on the latest production information available at the time of publication. Prices, materials, and specification are subject to change at any time, and models may be discontinued at any time, in either case, without notice or obligation.

UNIVERSAL VALVE COMPANY

478 Schiller Street, Elizabeth, NJ 07206 • (800) 223-0741 • (908) 351-0606 • Fax: (908) 351-0369 • universalvalve.com

© 2017 Universal Valve Company, Inc.