



Quality and Reliability, Since 1932!

AIR INFLATORS

AIR TOWERS

Application -

An Air Tower that is customizable to compliment all store designs.

Part Number - 1975-, 1975W

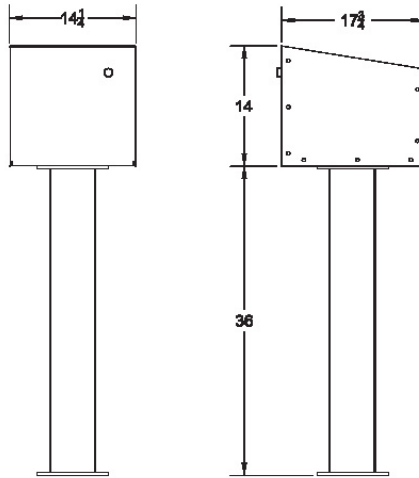

Features -

- ✓ Rugged Construction
- ✓ Solid State timer
- ✓ 25 ft abrasion and weather resistant air hose
- ✓ Heavy duty tire pressure gauge
- ✓ 3/4 HP. 110v CSA listed, continuous duty oilless compressor
- ✓ Maximum inflation of 125 psi.
- ✓ Post (1975-) and Wall (1975W) mounts available
- ✓ Standard Stainless steel
- ✓ Custom colors and graphics available
- ✓ Designed to operate below freezing
- ✓ Painted Post
- ✓ All components UL listed

Construction -

- 16 Gauge metal housing
- Stainless steel

| Model | Description | Weight (lbs.) |
|-----------------|--|---------------|
| 1975-CO34-SS | Post mount Coin operated | 90 |
| 1975W-CO34-SS | Wall mount Coin operated | 70 |
| 1975-CO34-SS-C | Post mount Coin operated w/counter | 90 |
| 1975W-CO34-SS-C | Wall mount Coin operated w/counter | 70 |
| 1975-FA34-SS | Post mount Free Air | 90 |
| 1975W-FA34-SS | Wall mount Free Air | 70 |
| 1975-FA34-SS-C | Post mount Free Air w/counter | 90 |
| 1975W-FA34-SS-C | Wall mount Free Air w/counter | 70 |
| 1975-34G | Compressor Relief Valve Valve-Gast Compressor | |

UNIVERSAL Advantage

Universal's built tough air tower is designed to operate in high heat and freezing conditions.

Replacement Parts

| Part Numbers | Description |
|------------------|---|
| 1975-22-SS | Wall mount Bracket |
| 1975-HDPOST | Heavy Duty Post assembly (Painted) |
| 1975-POST-SS | Post Assembly (Stainless Steel) -optional |
| 1975-16 | Free Air Push Button |
| 1975-14 | Tamper Proof Screw |
| 1975-14-TOOL | Tamper Proof Screwdriver |
| 1975-33 | Coin Box |
| 1975-33-F | Coin Box Funnel |
| 1975-15-A | Free Air Timer |
| 1975-COISW | Coin Switch |
| 1975-15 | Coin Timer |
| 1975-3 | Circuit Breaker |
| 1975-17 | Door Lock Assembly |
| 1975-CYCOUNT | Cycle Counter |
| 1975-20 | Tire Chuck and Gauge |
| 1975-19 | Air Hose |
| 1975-19M | Air Hose w/ metal braiding |
| 1975-COMPR-G | Air Compressor – Gast Compressor |
| 1975-35 | Air Compressor Air Filter |
| 1975-WARN | “Warning” Sticker |
| 1975-AIRST | “Air” Sticker |
| 1975-FRAR | “Free Air “ Sticker |
| 1975-STINS | “Instructions” Sticker for Free Air |
| 1975-IN25 | “25 cents” Instruction Sticker |
| 1975-IN50 | “50 cents” Instruction Sticker |
| 1975-KEY | Door Key |
| 1975-LK | Heavy Duty Lock Kit |
| 1975-PBHES | Push Button Label -Hess |
| 1975-FAHES | Free Air Label -Hess |
| 1975-AIRHES | Air Label -Hess |
| 1975-34 | Compressor Relief Valve |
| 1975-37 | Air Pressure Relief Valve |
| 1975-FACHASSIS-G | Complete Chassis Free Air – Gast Compressor |
| 1975-COCHASSIS-G | Complete Chassis Coin Operated – Gast Compressor |
| 1975-35G | Air Compressor Air Filter – Gast Compressor |

Notice: Universal Valve Co., products must be used in compliance with applicable federal, state, and local laws and regulations. Product selection should be based on physical specifications and limitations and compatibility with the environment and material to be handled. Universal Valve Co., makes no warranty of fitness for a particular use. All illustrations and specifications in this literature are based on the latest production information available at the time of publication. Prices, materials, and specification are subject to change at any time, and models may be discontinued at any time, in either case, without notice or obligation.

UNIVERSAL VALVE COMPANY

478 Schiller Street, Elizabeth, NJ 07206 • (800) 223-0741 • (908) 351-0606 • Fax: (908) 351-0369 • universalvalve.com

© 2012 Universal Valve Company, Inc.