



The Best For Over 75 Years!



MULTI-PURPOSE MANHOLES

ROUND RAIN-TIGHT GASKETED MANHOLES

Application -

A wide variety of service station, commercial, and industrial applications. Provides access to underground equipment. Recommended for high-traffic applications where manhole strength is required.

Part Number - 78 Patent number 5,899,629 and 5,785,452



Patented Concrete Lock

Features -

- ✓ Gasketed, bolted cover for total rain-tight service
- ✓ Convenient handle lies "flush" with the surface to eliminate tripping accidents and obstruction
- ✓ Welded and reinforced for maximum strength and longevity
- ✓ Rugged cast-iron for maximum strength
- ✓ Patented bottom flair locks in concrete
- ✓ H-20 Load rating
- ✓ Compatible with E-85

UNIVERSAL Advantage

Our galvanized skirts offer superior rust protection over industry style "painted only" skirts. A bottom concrete lock and anti deformation lip is standard on all 68 and 78 series. **Eliminates any loading onto the sump and tank caused by interference.** Better cover thickness for maximum strength. All of our 30" and 36" covers have a full 1/2" cover thickness, while industry uses only 3/8". Universal manhole covers never bend or wobble.

Construction -

- Fabricated steel ring
- Buna-N gaskets
- Steel diamond plate cover
- 12 gauge galvanized skirts

Model	Size	Weight (lbs.)	A	B	C	D	Cover Thickness
78-2410	24" x 10"	98	10"	22-1/4"	23-11/16"	26"	3/8"
78-3010	30" x 10"	142	10"	28-1/4"	29-11/16"	32"	1/2"
78-3610	36" x 10"	188	10"	34-1/4"	35"	38"	1/2"
78-3810	38" x 10"	216	10"	38"	39-1/2"	41"	1/2"
78-4210	42" x 10"	240	10"	40-1/4"	41"	44"	1/2"
78-4810	48" x 10"	313	10"	46-1/4"	47"	50"	1/2"

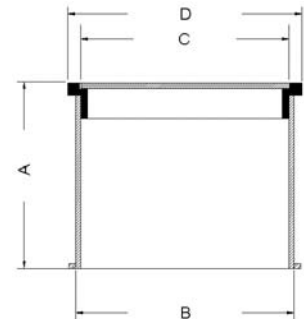

Replacement Parts

Part Numbers	Description	Part Numbers	Description
78-2410-WOC	24" Bolt Down Ring and skirt	88-24-A1	24" Diamond Plate Cover
78-3010-WOC	30" Bolt Down Ring and skirt	88-30-A1	30" Diamond Plate Cover
78-3610-WOC	36" Bolt Down Ring and skirt	88-36-A1	36" Diamond Plate Cover
78-4210-WOC	42" Bolt Down Ring and skirt	88-38-A1	38" Diamond Plate Cover
78-4810-WOC	48" Bolt Down Ring and skirt	88-42-A1	42" Diamond Plate Cover
78-BT	Bolt (Model 78)	88-48-A1	48" Diamond Plate Cover
78-GASKET	Gasket Tape		

Notice: Universal Valve Co., products must be used in compliance with applicable federal, state, and local laws and regulations. Product selection should be based on physical specifications and limitations and compatibility with the environment and material to be handled. Universal Valve Co., makes no warranty of fitness for a particular use. All illustrations and specifications in this literature are based on the latest production information available at the time of publication. Prices, materials, and specification are subject to change at any time, and models may be discontinued at any time, in either case, without notice or obligation.

UNIVERSAL VALVE COMPANY

478 Schiller Street, Elizabeth, NJ 07206 • (800) 223-0741 • (908) 351-0606 • Fax: (908) 351-0369 • universalvalve.com

© 2009 Universal Valve Company, Inc.