



The Best For Over 75 Years!

MONITORING WELL MANHOLES

ROUND NON-BOLTED

Application -

Monitoring well applications where limited access is not needed. Simple and economical. Has a cast iron ring and cover marked "monitoring well"

Part Number - 60MW



API Monitoring well designation

UNIVERSAL Advantage

Only Universal provides a galvanized steel skirt, providing rust-free, long-life performance at no extra cost.

Features -

- ✓ Clearly marked rugged cast iron covers and rings with "Monitoring Well" designation, in accordance with API-RP-1615
- ✓ Remove cover with easy-open slots
- ✓ Carries H-20 load rating
- ✓ Custom skirt lengths available

Construction -

- Cast iron cover and ring
- Polymeric coating
- 18 gauge galvanized steel skirt

Model	Size	Weight (lbs.)	A	B	C	D
60MW-1280	12" x 8"	25	7-1/2"	12-1/4"	12"	13-7/8"
60MW-1212	12" x 12"	26	13-1/8"	12-1/4"	12"	13-7/8"

Replacement Parts

Part Numbers	Description
1300-246	Pop Rivet
60-12-A5	12" Ring only
60-12-C3	12" x 6" Skirt
60MW-12-B3	12" MW Cover only
65-12-C2	12" x 12" Skirt

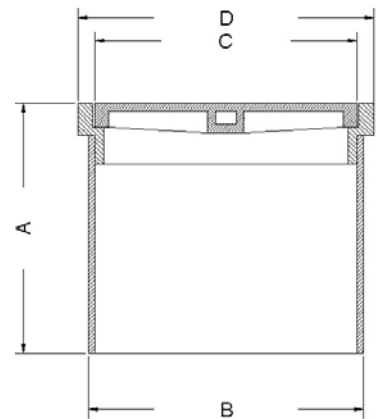

Notice: Universal Valve Co., products must be used in compliance with applicable federal, state, and local laws and regulations. Product selection should be based on physical specifications and limitations and compatibility with the environment and material to be handled. Universal Valve Co., makes no warranty of fitness for a particular use. All illustrations and specifications in this literature are based on the latest production information available at the time of publication. Prices, materials, and specification are subject to change at any time, and models may be discontinued at any time, in either case, without notice or obligation.

UNIVERSAL VALVE COMPANY

478 Schiller Street, Elizabeth, NJ 07206 • (800) 223-0741 • (908) 351-0606 • Fax: (908) 351-0369 • universalvalve.com

© 2009 Universal Valve Company, Inc.