

Model 39 Overfill Protection Valve FOR UNDERGROUND STORAGE TANKS

INSTALLATION INSTRUCTIONS

UNIVERSAL VALVE COMPANY, INC. 478 SCHILLER ST. ELIZABETH, NJ 07206

Rev A

Installation Instructions

The Model 39 Overfill Protection Valve is designed to prevent the overfill of underground fuel storage tanks during product drops. The valve operates automatically when product reaches a predetermined level and gradually slows flow down to allow the operator time to shut the product drop off. After the product drop has been shut off, the remaining fluid in the line is drained automatically into the tank. For safety, the valve should be used in conjunction with a Spill Containment Manhole.

Important Note Prior to installation read these instructions completely. Check to make sure all parts are included. Do not substitute parts for those provided, unless specified. Failure to properly follow these instructions may result in improper operation of the valve.

Parts List

Needed

1. Drill
2. Measuring Tape
3. Hammer
4. Hacksaw
5. File or other Deburring tool
6. Permanent Marker
7. Bearing Grease or Oil
8. Sharp or new 1/8" Drill Bit

Included

- (1) Model 39 Valve Assembly
- (2) Drop Tube O-Rings
- (2) Drop Tube Halves (Model 723)
- (6) 10-24 Countersink Mounting Screws
- (1) Countersink Punch Assembly
- (2) Drill Templates

Warranty Statement

All UNIVERSAL products are guaranteed to be free from defects in materials and workmanship. All products are thoroughly tested before shipment and guaranteed to the extent of replacing only products found to be defective in manufacture. We cannot, however, allow claims for labor or consequential damage resulting from purchase, installation or misapplication of our products.

Our responsibility ceases when products are accepted by transportation carriers. All goods are at the risk of the purchaser after they have been delivered by us to the carrier and receipt obtained from same (in good order).

The right is reserved to make changes in pattern, design or materials when deemed necessary, without prior notice. Products, which have become obsolete by reason of design change or discontinued, as a manufactured item may not be returned for credit.

THIS WARRANTY IS IN LIEU OF ALL OTHER WARRANTIES, EXPRESS OR IMPLIED, AND SPECIFICALLY THE WARRANTIES OF MERCHANTABILITY AND FITNESS FOR A PARTICULAR PURPOSE.

Warning *Universal Valve products should be used in compliance with applicable federal, state and local laws and regulations. Product selection should be based on physical specifications and limitations and compatibility with environment and material to be handled. Universal Valve makes no warranty of fitness for a particular use*

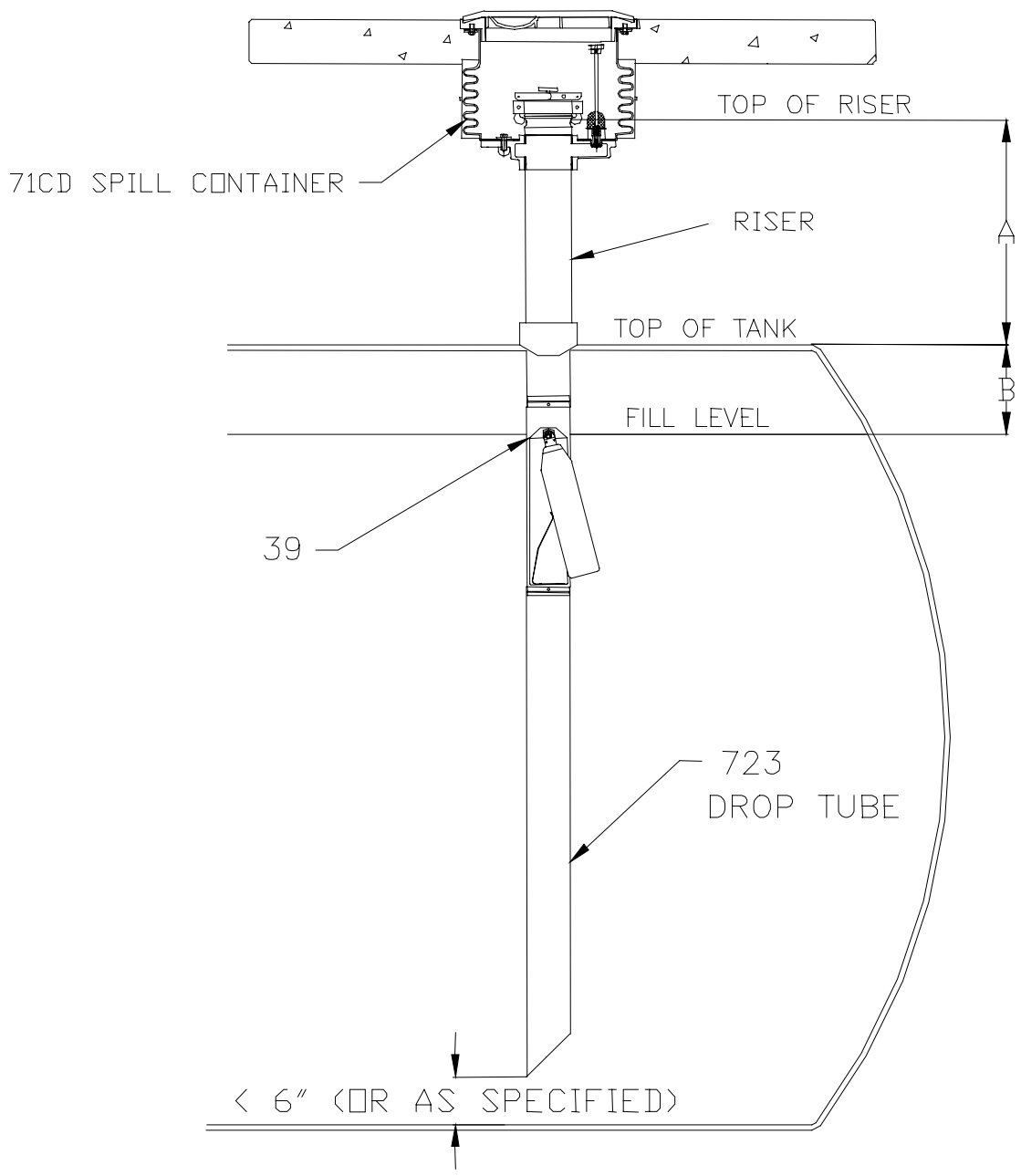

Figure 1

Instructions

1. Extract Drop Tube from tank by removing adaptor (use Model 724-7W Adaptor Wrench for easy removal) and pulling drop tube straight up out of tank. If drop tube is supplied with valve, discard old drop tube. If old drop tube is being used, put aside for later use. *Note: It is highly recommended to replace the drop tube for this installation due to the variety of sizes and configurations in the field.*
2. Measure the vertical distance from riser pipe lip to top of tank. This will be dimension A as shown in Figure 1.
3. Determine distance, "B" for shut off point from chart below.

Tank Diameter [ft]	"B" Dimension for 95% Shut Off	"B" Dimension for 90% Shut Off
4	4 ¾"	7 ½"
5	6"	9 ½"
6	7"	11 ¼"
7	8 ¼"	13 ¼"
8	9 ½"	15"
9	10 ½"	17"
10	11 ¾"	18 ¾"
11	13"	20 ¾"
12	14"	22 ½"

Values given are approximate. Exact values can be calculated from the following equations:

*For 95% shut off, Distance from top (in inches) = 1.1677 * Diameter of Tank (in feet)*

*For 90% shut off, Distance from top (in inches) = 1.8777 * Diameter of Tank (in feet)*

4. Use hacksaw to cut supplied drop tube $2 \frac{1}{2}$ " shorter than the sum of these two distances
(Drop tube length = dimension A + dimension B – $2 \frac{1}{2}$ ").
Measure distance from flared end of drop tube. *Be sure to debur the cut edge of the drop tube to prevent tearing of o-ring when valve is inserted into drop tube.*
5. Use supplied templates to drill three equally spaced $\frac{1}{4}$ " holes in the drop tube $\frac{5}{8}$ " from the cut edge for the top portion of the drop tube and $\frac{1}{2}$ " from the cut edge for the lower portion of the drop tube.
6. Remove O-Ring from valve. Align holes in drop tube with threaded holes in Valve body. Use supplied countersink to create countersink in each hole by threading post into Valve body and tightening down to create indentation in drop tube over countersink in Valve Body.
7. Use included Ready Mix Epoxy Packs to put a bead of epoxy around undercut for drop tube on valve. Be careful to keep the bead of epoxy away from the o-ring groove to prevent clogging of o-ring seat.
8. Carefully attach O-Ring onto Valve. Insert Model 39 into top piece of drop tube, using oil or grease to assist in sliding over O-Ring. *To avoid tearing the O-Ring, debur the holes just drilled before inserting valve.*
9. Fasten Valve to Drop Tube using three 10-24 countersink screws supplied.
10. Slide lower section of drop tube over bottom half of valve, being sure to use oil or grease to slide over o-ring as done in Step 6. Repeat Steps 6 - 8 for lower half of drop tube.
11. Adjust overall length of 39/drop-tube assembly by cutting a 45° angle on open end of drop tube. Make sure the bottom edge of the drop tube is the desired distance from bottom of tank. (6 " from bottom or as per local requirements)

12. Clean and debur inside of riser pipe to prevent damage to valve and float while inserting.
13. Insert drop tube and valve assembly straight into tank. Be sure to push float completely against valve body (poppet completely open) against preset spring so that the float will be able to be inserted into the riser pipe. When the valve clears the riser inside the tank, the float will pop back into its preset position. *Note: make sure there is a rubber gasket under flange of upper drop tube. Do not force valve into riser, if the valve does not fit, clean the interior of the riser and re-insert valve/drop tube assembly.*
14. Reinstall tight fill adaptor and gasket and tighten. Valve is now ready for operation.

Model Numbers

Model Number	Description
Model 39-0508	Standard Model for tanks up to 10 feet
Model 39-0508CA	Coaxial Model for tanks up to 10 feet
Model 39-0710	Standard Model for tanks up to 12 feet
Model 39-0710CA	Coaxial Model for tanks up to 12 feet
Model 39-04	Standard Model without Drop Tube

Product Specifications

Dimensions

Part	Dimension
Upper drop Tube (Model 39-0508)	5 feet long x Standard 4" diameter
Lower Drop Tube (Model 39-0508)	8 feet long x Standard 4" diameter
Upper drop Tube (Model 39-0710)	7 feet long x Standard 4" diameter
Lower Drop Tube (Model 39-0710)	10 feet long x Standard 4" diameter
Valve Body Length	18"

Material

Part	Material
Upper drop Tube	Aluminum
Lower Drop Tube	Aluminum
Valve Body	Hardcoated Cast Aluminum
Poppet	Hardcoated Cast Aluminum
Shaft	Stainless Steel
Thrust Bearing	Stainless Steel
Interior O-Ring Seal	Buna
Exterior Washer	Teflon
Float	Closed Cell Buna Foam
Hex Poppet Shaft Guide	T6 Aluminum

Miscellaneous Info.

- No Minimum flow Rate for Operation.
- Can be used in conjunction with Ball Float Vent valves.
- Can be used in conjunction with Piccolo Vapor Reduction system.
- Valve assembly weight 5 lbs.

Maintenance Info:

- Annual inspection for visual defects and manual inspection that arm swings freely.