

# ***Universal Valve Co., Inc.***



**Increase Profits at your Retail Facilities Today!**

***Advertise  
at the  
Pump!***



***Increase  
Consumer  
Loyalty!***



***Keep Your  
Sites Looking  
Great!***

**www.universalvalve.com  
sales@universalvalve.com  
800-223-0741**

**Rev. 7-18**



Everybody **LOVES** free Air! Install Tire Inflators and build consumer loyalty and more c-store traffic.

More profits in your store!



Now that you have their attention make sure your store looks great too! Cover up those unsightly steel bollards with Universal Bollard Covers that are UV stable and will not fade. 10 colors to choose from. 7 different reflective tapes too!



Research shows over 65% of your customers that fuel up never enter your store.

Outside signage at the pump is the number one recommendation to increase sales in your store.

By utilizing signage at the pump 100% of your customers that are fueling their vehicles will be aware of your in-store specials.

Simple installation and easy poster change out make sales specials a snap to update.

Customizable to match your stores décor.

Available in standard and rounded corners.

Call Today to start increasing your C-store sales.



**Quality and Reliability, Since 1932!**

# AIR INFLATORS

## AIR TOWERS - FREE AIR

### Application -

An Air Tower that is customizable to compliment all store designs.

### Part Number - 1975-, 1975W

# UNIVERSAL Advantage

Universal's built tough air tower is designed to operate in high heat and freezing conditions.

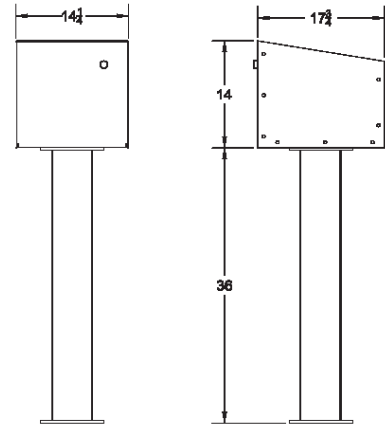

### Features -

- ✓ Rugged Construction
- ✓ Solid State timer
- ✓ 25 ft abrasion and weather resistant air hose
- ✓ Heavy duty tire pressure gauge
- ✓ 1/2 HP oilless compressor
- ✓ Maximum inflation of 100 psi.
- ✓ ETL Listed
- ✓ Stainless Steel Cabinet
- ✓ Painted Post (Optional Hot Dip Galvanized)
- ✓ All components UL listed

### Construction -

- 16 Gauge metal housing
- Stainless steel
- Schedule 40 post

### FREE AIR

### Description

1975-FA12-175-SS	Post mount Stainless Steel 1/2hp HD Truck Comp (painted hd-post)
1975-FA12-175-HR-SS	Post mount Stainless Steel 1/2hp HD Truck Comp (painted hd-post) w/ Hose Reel
1975-FA34-SS	Post mount Stainless Steel (painted hd-post)
1975-FA34-HR-SS	Post mount Stainless Steel (painted hd-post)w/ Hose Reel
1975-FA34-HR-GSS	Post mount Stainless Steel (Galvanized hd-post)w/ Hose Reel
1975-FASV-SS	Post mount Stainless Steel Solenoid valve no internal Comp (painted hd-post)
1975W-FA34-SS	Wall mount Stainless Steel
1975W-FASV-SS	Wall mount Stainless Steel Solenoid valve no internal Comp.

Notice: Universal Valve Co., products must be used in compliance with applicable federal, state, and local laws and regulations. Product selection should be based on physical specifications and limitations and compatibility with the environment and material to be handled. Universal Valve Co., makes no warranty of fitness for a particular use. All illustrations and specifications in this literature are based on the latest production information available at the time of publication. Prices, materials, and specification are subject to change at any time, and models may be discontinued at any time, in either case, without notice or obligation.

## UNIVERSAL VALVE COMPANY

478 Schiller Street, Elizabeth, NJ 07206 • (800) 223-0741 • (908) 351-0606 • Fax: (908) 351-0369 • [universalvalve.com](http://universalvalve.com)

© 2020 Universal Valve Company, Inc.



**Quality and Reliability, Since 1932!**

# AIR INFLATORS

## AIR TOWERS - COIN OPERATED

### Application -

An Air Tower that is customizable to compliment all store designs.

### Part Number - 1975-, 1975W

# UNIVERSAL Advantage

Universal's built tough air tower is designed to operate in high heat and freezing conditions.

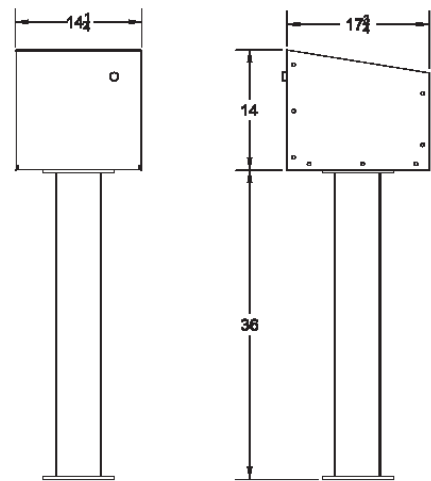

### Features -

- ✓ Rugged Construction
- ✓ Solid State timer
- ✓ 25 ft abrasion and weather resistant air hose
- ✓ Heavy duty tire pressure gauge
- ✓ 1/2 HP oilless compressor
- ✓ Maximum inflation of 100 psi.
- ✓ ETL Listed
- ✓ Stainless Steel Cabinet
- ✓ Painted Post (Optional Hot Dip Galvanized)
- ✓ All components UL listed

### Coin Operated

### Description

1975-CO34-SS	Post mount Stainless Steel (painted hd-post)
1975-CO34-HR-SS	Post mount Stainless Steel (painted hd-post)w/ Hose Reel
1975-CO34-HR-GSS	Post mount Stainless Steel (Galvanized hd-post)w/ Hose Reel
1975W-CO34-SS	Wall mount Stainless Steel
1975-CO34-SS-C	Post mount Stainless Steel w/ counter (painted hd-post)
1975W-CO34-SS-C	Wall mount Stainless Steel w/ counter

### Construction -

- 16 Gauge metal housing
- Stainless steel
- Schedule 40 post

Notice: Universal Valve Co., products must be used in compliance with applicable federal, state, and local laws and regulations. Product selection should be based on physical specifications and limitations and compatibility with the environment and material to be handled. Universal Valve Co., makes no warranty of fitness for a particular use. All illustrations and specifications in this literature are based on the latest production information available at the time of publication. Prices, materials, and specification are subject to change at any time, and models may be discontinued at any time, in either case, without notice or obligation.

**UNIVERSAL VALVE COMPANY**

478 Schiller Street, Elizabeth, NJ 07206 • (800) 223-0741 • (908) 351-0606 • Fax: (908) 351-0369 • universalvalve.com

© 2020 Universal Valve Company, Inc.





Family Owned Over 80 Years. We Care!

# ACCESSORIES

## BOLLARD COVERS

### Application -

Bollard covers enhance and protect the appearance of bumper post steel bollards in all indoor and outdoor applications.

### Part Number - 1984-BC



### Features -

- ✓ 10 Standard colors
- ✓ 7 Reflective tape colors
- ✓ 8 Standard sizes for 4", 6", 8", & 10"
- ✓ Patented GripperTabs™ installation is the fastest and easiest way to secure bollard covers

### Construction -

- 1/8" thick Polyethylene
- 3M #680 reflective tape

Model	Description
1984-BC452	4"x52" Bollard Cover
1984-BC464	4"x64" Bollard Cover
1984-BC752	7"x52" Bollard Cover
1984-BC760	7"x60" Bollard Cover
1984-BC772	7"x72" Bollard Cover
1984-BC872	8"x72" Bollard Cover
1984-BC1060	11"x60" Bollard Cover

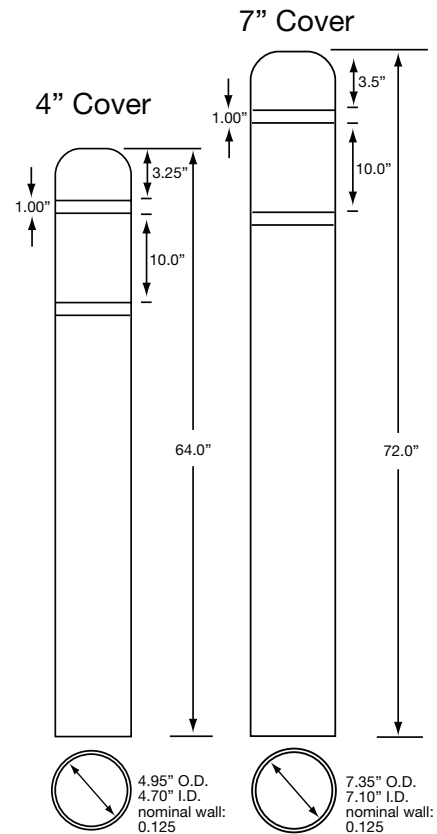

### Colors Available

Bollard Cover Colors:		Tape Colors:	
Red	(R)	Red	(R)
Orange	(O)	Orange	(O)
Yellow	(Y)	Yellow	(Y)
Green	(G)	Green	(G)
Blue	(B)	Blue	(B)
White	(W)	White	(W)
Brown	(BN)	Black	(BK)
Tan	(T)		
Gray	(GY)		
Black	(BK)		

Notice: Universal Valve Co., products must be used in compliance with applicable federal, state, and local laws and regulations. Product selection should be based on physical specifications and limitations and compatibility with the environment and material to be handled. Universal Valve Co., makes no warranty of fitness for a particular use. All illustrations and specifications in this literature are based on the latest production information available at the time of publication. Prices, materials, and specification are subject to change at any time, and models may be discontinued at any time, in either case, without notice or obligation.

UNIVERSAL VALVE COMPANY

478 Schiller Street, Elizabeth, NJ 07206 • (800) 223-0741 • (908) 351-0606 • Fax: (908) 351-0369 • universalvalve.com

© 2020 Universal Valve Company, Inc.



**Proven Performance Since 1932.**

# UNIVERSAL SIGNAGE SYSTEMS

## BUMPERBOARD™ U-Shaped Guard Mount

### Application -

Increase profits by utilizing existing space on your pipe guards.  
Promote in store specials at the pump with Universal's BumperBoard sign.

### Part Number - 1999-2844

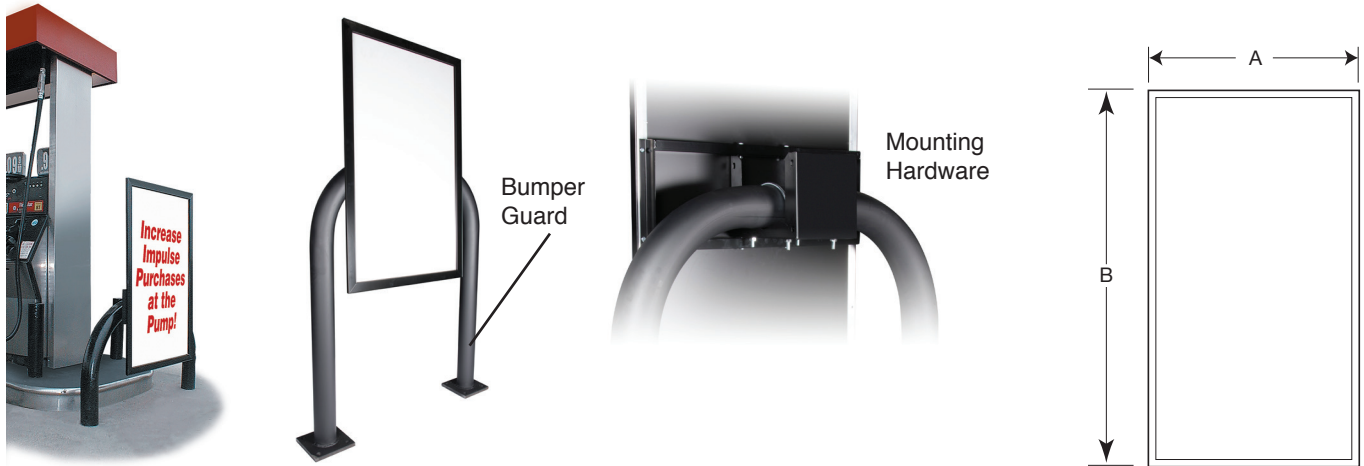

### Features -

- ✓ Increase profits by utilizing existing space
- ✓ It's a fact that the average consumer takes 6 minutes to fuel their car - you have their total attention
- ✓ Your customer will not miss your promotion as they pull up to the pump
- ✓ Mounts to standard bumper guard
- ✓ Easy front loading access for your message insert
- ✓ Rounded corners also available

### Construction -

- Epoxy coated aluminum frames
- Heavy duty spring clips

Model	Description	Weight (lbs)	A	B	Poster Insert Size
1999-2844	BumperBoard 28" x 44" w/ ubolt mounting box	22	29 -1/8"	45 -1/4"	28" x 44"
1999-2844-2	BumperBoard Secondary Sign 28" x 44" (no mounting bracket)	14	29 -1/8"	45 -1/4"	28" x 44"
1999-2844-RC	BumperBoard 28" x 44" w/ Rounded Corners w/u-bolt mounting box	22	29 -1/8"	45 -1/4"	27" x 43"
1999-2844-RC-2	BumperBoard 28" x 44" w/ Rounded Corners Secondary Sign (no mounting bracket)	14	29 -1/8"	45 -1/4"	27" x 43"
1999-2844-RC-MO	BumperBoard 28" x 44" w/ Rounded Corners w/ Murphy Oil u-bolt mounting box	22	29 -1/8"	45 -1/4"	27" x 43"
1999-3644	BumperBoard 36" x 44" w/ ubolt mounting box	25	37 -1/8"	45 -1/4"	36" x 44"
1999-3644-2	BumperBoard Secondary Sign 36" x 44" (no mounting bracket)	25	37 -1/8"	45 -1/4"	36" x 44"
1999-U	U-bolt Mounting Box (formerly 1999-2844-U) Up to 4.5" O.D. pipe	8	-	-	-
1999-U-MO	U-bolt Mounting Box- Murphy Oil-w/special cover (formerly 1999-2844-U-MO)	8	-	-	-

Notice: Universal Valve Co., products must be used in compliance with applicable federal, state, and local laws and regulations. Product selection should be based on physical specifications and limitations and compatibility with the environment and material to be handled. Universal Valve Co., makes no warranty of fitness for a particular use. All illustrations and specifications in this literature are based on the latest production information available at the time of publication. Prices, materials, and specification are subject to change at any time, and models may be discontinued at any time, in either case, without notice or obligation.

### UNIVERSAL VALVE COMPANY

478 Schiller Street, Elizabeth, NJ 07206 • (800) 223-0741 • (908) 351-0606 • Fax: (908) 351-0369 • universalvalve.com

© 2020 Universal Valve Company, Inc.



**Proven Performance Since 1932.**

# UNIVERSAL SIGNAGE SYSTEMS

## BUMPERBOARD™ Dual Bollard Mount

### Application -

Increase profits by utilizing existing space between two bollards with Universal's dual bollard mount signage system.

### Part Number - 1999-2844

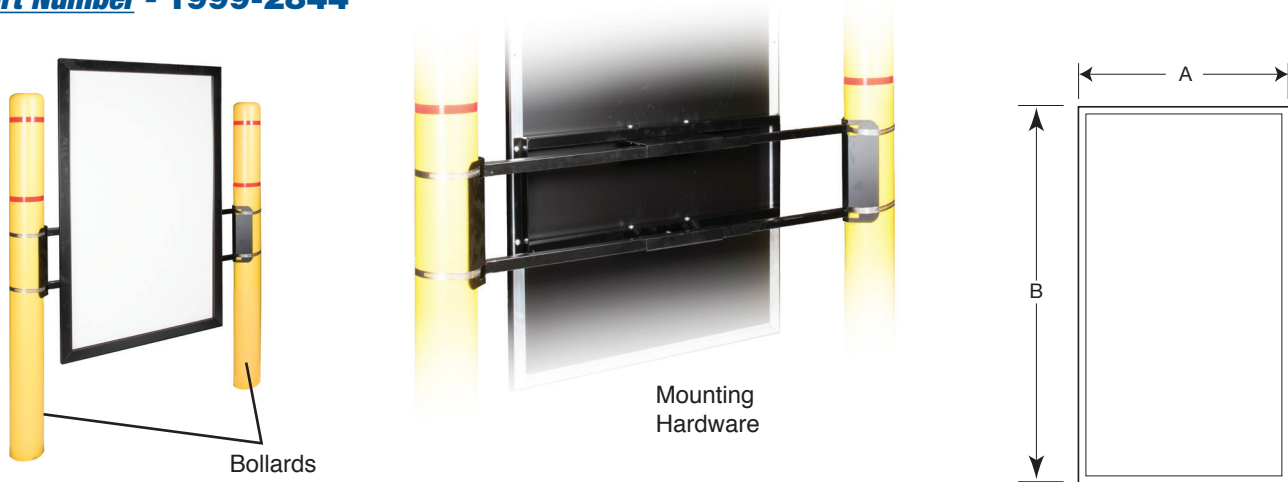

### Features -

- ✓ Increase profits by utilizing existing space
- ✓ It's a fact that the average consumer takes 6 minutes to fuel their car - you have their total attention
- ✓ Your customer will not miss your promotion as they pull up to the pump
- ✓ Mounts to dual bollards
- ✓ Easy front loading access for your message insert
- ✓ Rounded corners also available

### Construction -

- Epoxy coated aluminum frames
- Heavy duty spring clips

Model	Description	Weight (lbs)	A	B	Poster Insert Size
1999-2844-BM	Standard 28" x 44" Sign with Dual Bollard mounting Bracket (formerly 1999-BM-2)	30	29 -1/8"	45 -1/4"	28" x 44"
1999-2844-BM20	Standard 28" x 44" Sign with Dual Bollard mounting Bracket Bollard Span (20"x38")	15	29 -1/8"	45 -1/4"	28" x 44"
1999-2844-2	BumperBoard Secondary Sign 28" x 44" (no mounting bracket)	14	29 -1/8"	45 -1/4"	28" x 44"
1999-2844-RC-2	BumperBoard 28" x 44" w/ Rounded Corners Secondary Sign (no mounting bracket)	14	29 -1/8"	45 -1/4"	27" x 43"
1999-3644-BM	Standard 36" x 44" Sign with Dual Bollard mounting Bracket (formerly 1999-BM-2)	25	37 -1/8"	45 -1/4"	36" x 44"
1999-3644-2	BumperBoard Secondary Sign 36" x 44" (no mounting bracket)	25	37 -1/8"	45 -1/4"	36" x 44"
1999-BM	Dual Bollard Mounting Bracket Bollard Span (28" x 48")	15	-	-	-
1999-BM20	Dual Bollard Mounting Bracket Bollard Span (20" x 38")	15	-	-	-

Notice: Universal Valve Co., products must be used in compliance with applicable federal, state, and local laws and regulations. Product selection should be based on physical specifications and limitations and compatibility with the environment and material to be handled. Universal Valve Co., makes no warranty of fitness for a particular use. All illustrations and specifications in this literature are based on the latest production information available at the time of publication. Prices, materials, and specification are subject to change at any time, and models may be discontinued at any time, in either case, without notice or obligation.

### UNIVERSAL VALVE COMPANY

478 Schiller Street, Elizabeth, NJ 07206 • (800) 223-0741 • (908) 351-0606 • Fax: (908) 351-0369 • universalvalve.com

© 2020 Universal Valve Company, Inc.



**Proven Performance Since 1932.**

# UNIVERSAL SIGNAGE SYSTEMS

## BUMPERBOARD™ Single Bollard/Pole Mount

### Application -

Increase profits by promoting utilizing existing space on bollards with Universal's single bollard mounting system.

### Part Number - 1999-2844



### Features -

- ✓ Increase profits by utilizing existing space
- ✓ It's a fact that the average consumer takes 6 minutes to fuel their car - you have their total attention
- ✓ Your customer will not miss your promotion as they pull up to the pump
- ✓ Mounts to round or square poles
- ✓ Easy front loading access for your message insert
- ✓ Rounded corners also available

### Construction -

- Epoxy coated aluminum frames
- Heavy duty spring clips

Model	Description	Weight (lbs)	A	B	Insert Size
1999-2844	BumperBoard 28" x 44" w/ ubolt mounting box	22	29 -1/8"	45 -1/4"	28" x 44"
1999-2844-2	BumperBoard Secondary Sign 28" x 44" (no mounting bracket)	14	29 -1/8"	45 -1/4"	28" x 44"
1999-2844-RC	BumperBoard 28" x 44" w/ Rounded Corners w/u-bolt mounting box	22	29 -1/8"	45 -1/4"	27" x 43"
1999-2844-RC-2	BumperBoard 28" x 44" w/ Rounded Corners Secondary Sign (no mounting bracket)	14	29 -1/8"	45 -1/4"	27" x 43"
1999-3644	BumperBoard 36" x 44" w/ ubolt mounting box	25	37 -1/8"	45 -1/4"	36" x 44"
1999-3644-2	BumperBoard Secondary Sign 36" x 44" (no mounting bracket)	25	37 -1/8"	45 -1/4"	36" x 44"
1999-SQ	Square Pole Mounting Box (up to 5.25" o.d.)	10	-	-	-
1999-U	U-bolt Mounting Box (formerly 1999-2844-U) Up to 4.5" OD Pipe	8	-	-	-
1999-U-MO	U-bolt Mounting Box- Murphy Oil-w/special cover (formerly 1999-2844-U-MO) Up to 4.5" OD Pipe	8	-	-	-

Notice: Universal Valve Co., products must be used in compliance with applicable federal, state, and local laws and regulations. Product selection should be based on physical specifications and limitations and compatibility with the environment and material to be handled. Universal Valve Co., makes no warranty of fitness for a particular use. All illustrations and specifications in this literature are based on the latest production information available at the time of publication. Prices, materials, and specification are subject to change at any time, and models may be discontinued at any time, in either case, without notice or obligation.

### UNIVERSAL VALVE COMPANY

478 Schiller Street, Elizabeth, NJ 07206 • (800) 223-0741 • (908) 351-0606 • Fax: (908) 351-0369 • universalvalve.com

© 2020 Universal Valve Company, Inc.



**Quality and Reliability, Since 1932!**

# SIGNAGE

## PUMP TOPPER

### **Application -**

Mounts to the top of the dispenser, advertising in store specials.

### **Part Number - 1997**



### **Features -**

- ✓ Standard size 12" x 20"
- ✓ Highlights your offers and specials
- ✓ Enhances your fueling sites
- ✓ Grabs attention and maximizes sales volume
- ✓ Standard color black
- ✓ Custom colors available
- ✓ Top loading inserts

### **Construction -**

- Painted aluminum frame
- Heavy duty mounting tape

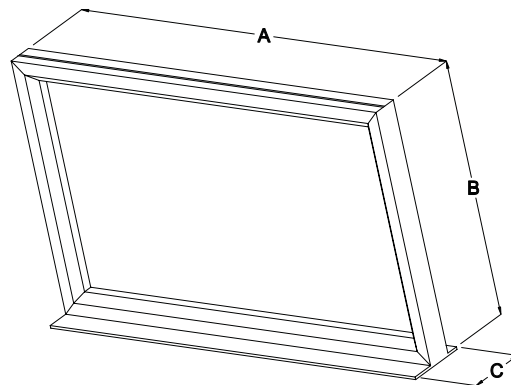

Model	Weight (lbs.)	A	B	C
1997-1220	2.00	20-1/2"	12-1/2"	3-1/4"

Notice: Universal Valve Co., products must be used in compliance with applicable federal, state, and local laws and regulations. Product selection should be based on physical specifications and limitations and compatibility with the environment and material to be handled. Universal Valve Co., makes no warranty of fitness for a particular use. All illustrations and specifications in this literature are based on the latest production information available at the time of publication. Prices, materials, and specification are subject to change at any time, and models may be discontinued at any time, in either case, without notice or obligation.

**UNIVERSAL VALVE COMPANY**

478 Schiller Street, Elizabeth, NJ 07206 • (800) 223-0741 • (908) 351-0606 • Fax: (908) 351-0369 • [universalvalve.com](http://universalvalve.com)

© 2020 Universal Valve Company, Inc.





**The Best For Over 75 Years!**

# UNIVERSAL SIGNAGE SYSTEMS

## THE WALLI™

### Application -

Mounts to any window, wall or vertical space to highlight your offerings.

### Part Number - 1999-Walli



# UNIVERSAL Advantage

The Universal Sign System Strategically Brings Your Customer Into The Store...Ready To Spend... Because It's The **ONLY** Sign System That Starts At The Pump, And Finishes In The Store.

### Features -

- ✓ Highlights your offers and specials
- ✓ Stops consumers and brings them into your store
- ✓ Enhances your fueling sites
- ✓ Available in standard or rounded corners
- ✓ Grabs attention and maximizes sales volume
- ✓ Standard size 28" x 44"
- ✓ Custom sizes available
- ✓ Easy front loading access for your message insert

### Construction -

- Epoxy coated steel frames
- Heavy duty spring clips
- Sign inserts available with any graphics, messages, and logos
- Rounded corners also available

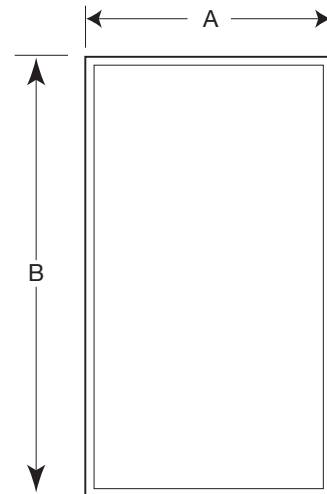

Model#	Description	Weight (lbs.)
1999-WALLI	28" x 44" Wall mount sign	14
1999-WALLI-RC	28" x 44" Wall mount sign with rounded corners	14

Notice: Universal Valve Co., products must be used in compliance with applicable federal, state, and local laws and regulations. Product selection should be based on physical specifications and limitations and compatibility with the environment and material to be handled. Universal Valve Co., makes no warranty of fitness for a particular use. All illustrations and specifications in this literature are based on the latest production information available at the time of publication. Prices, materials, and specification are subject to change at any time, and models may be discontinued at any time, in either case, without notice or obligation.

### UNIVERSAL VALVE COMPANY

478 Schiller Street, Elizabeth, NJ 07206 • (800) 223-0741 • (908) 351-0606 • Fax: (908) 351-0369 • universalvalve.com

© 2020 Universal Valve Company, Inc.



**Family Owned Over 80 Years. We Care!**

## **ABSORBENTS**

### **The Ultimate 20 Gallon Emergency Spill Response Kit**

UN approved water and chemical resistant polyethylene container with ring clamp top lid. Equipped with Allwik absorbent products. Absorbs up to 20 gallons.

<b>Part Number</b>	<b>Size</b>
2005-SKA-20	(20) 15" x 19" Pads (3) 3" x 12' Socs (6) 18" x 18" Pillows (1) Goggle (1) Pair Nitrile Gloves (1) Pair Shoe Covers (3) Disposable Bags (3) Zip Ties



### **The Ultimate 55 Gallon Emergency Spill Response Kit**

UN approved water and chemical resistant polyethylene container with ring clamp top lid. Equipped with Allwik absorbent products. Absorbs up to 55 gallons.

<b>Part Number</b>	<b>Size</b>
2005-SKA-55	(50) Pads (15" x 19") (12) Socks (3" x 4") (8) Pillows (18" x 18") (1) Pair Goggles (5) Disposal Bags (1) Emergency Response Guidebook (1) Pair Nitrile Gloves



Notice: Universal Valve Co., products must be used in compliance with applicable federal, state, and local laws and regulations. Product selection should be based on physical specifications and limitations and compatibility with the environment and material to be handled. Universal Valve Co., makes no warranty of fitness for a particular use. All illustrations and specifications in this literature are based on the latest production information available at the time of publication. Prices, materials, and specification are subject to change at any time, and models may be discontinued at any time, in either case, without notice or obligation.

**UNIVERSAL VALVE COMPANY**

478 Schiller Street, Elizabeth, NJ 07206 • (800) 223-0741 • (908) 351-0606 • Fax: (908) 351-0369 • [universalvalve.com](http://universalvalve.com)

© 2020 Universal Valve Company, Inc.



**Quality and Reliability, Since 1932!**

## ACCESSORIES RE-USABLE PAINT TEMPLATES

# RE-USABLE PAINT TEMPLATES

### **Application -**

Simply place the templates in the order shown and apply paint.  
Plastic kits include 4 templates (3 circles and 1 cross).  
Separate diesel template also available. Consult API color chart for correct color selection.

### **Part Numbers - RM Template**

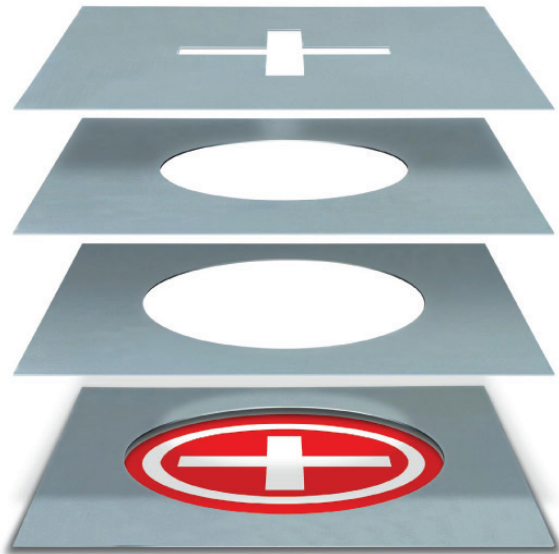

<b>Model</b>	<b>Description</b>
RM-20	20" Circle
RM-22-26	22"+24"+26" Circle Set
RM-Cross-P	Cross Shape
RM-Diesel-P	Plastic Diesel Hexagon Shaped Template
RM-Template-U	Plastic (U) Shaped Template
RM-Template-P	Set of 14"+16"+18" circle and a cross(+)

Notice: Universal Valve Co., products must be used in compliance with applicable federal, state, and local laws and regulations. Product selection should be based on physical specifications and limitations and compatibility with the environment and material to be handled. Universal Valve Co., makes no warranty of fitness for a particular use. All illustrations and specifications in this literature are based on the latest production information available at the time of publication. Prices, materials, and specification are subject to change at any time, and models may be discontinued at any time, in either case, without notice or obligation.

### **UNIVERSAL VALVE COMPANY**

478 Schiller Street, Elizabeth, NJ 07206 • (800) 223-0741 • (908) 351-0606 • Fax: (908) 351-0369 • [universalvalve.com](http://universalvalve.com)

© 2020 Universal Valve Company, Inc.

---

## ***Universal Valve Co., Inc.***

A leading manufacturer in the Petroleum Equipment Industry for over 85 years. Creating innovative, quality, reliable products for c-stores, gas stations and fueling facilities all over the world.

Call today to upgrade your site! Tire Inflators, Bollard Covers and At the Pump Signage.. Universal has you covered!



---

## **Universal Valve Co., Inc.**

**478 Schiller St.  
Elizabeth, NJ 07206**

**800-223-0741 Phone  
908-351-0606 Phone  
908-351-0369 fax  
[www.universalvalve.com](http://www.universalvalve.com)  
[sales@universalvalve.com](mailto:sales@universalvalve.com)**